

Series
RECOM S/SE/SF/SEF EC



Air handling units in heat- and sound-insulated casing.
Air flow up to **690 m³/h**.
Heat recovery efficiency up to **93 %**

■ **Description**

The air-handling units are the fully featured ventilation units with heat recovery for air filtration, fresh air supply and stale air extract. During operation the extract air heat is transferred to the supply air stream by the highly efficient plate heat exchanger.

The units are designed for energy efficient ventilation of cottages and flats and are compatible with round air ducts (Ø 125, 160 and 200 mm).

■ **Casing**

Made of high-quality polymer coated steel, internally filled with 20, 25, 30 or 40 mm (depending on the unit model) mineral wool layer for heat and sound insulation.

■ **Filter**

Supply and exhaust air is purified in panel filters with filtering class G4 and F7, respectively.

Supply air in the **RECOM S/SE/SF/SEF EC** units is purified by the G4 and F7 filters. Exhaust air is purified by the G4 filters.

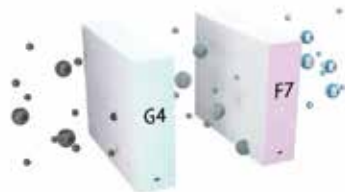

■ **Fans**

The units are equipped with high-efficient EC motors with an external rotor and a centrifugal impeller with backward curved blades. These state-of-the-art motors are the most advanced solution in energy efficiency today.

EC motors are characterised with high performance and optimum control across the entire speed range. In addition to that, the efficiency of the electronically commutated motor reaches very impressive levels of up to 90 %.

■ **Heat exchanger**

The **RECOM S/SF EC** units are equipped with a counter-flow polystyrene heat exchanger. In the cold season the extract air heat is captured and transferred to the supply air stream which reduces the ventilation-generated heat losses. This can lead to formation of condensate that is collected in a special drain pan and discharged into the sewage system.

In the warm season the ambient air heat is transferred to the exhaust air stream. This allows for a considerable reduction of the supply air temperature which, in turn, reduces the air conditioning load.

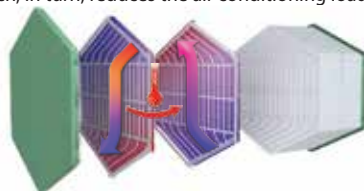

The **RECOM SE/SEF EC** units are equipped with a counterflow enthalpy heat exchanger. In the cold season the extract air heat and moisture are transferred to the supply air stream through the enthalpy heat exchanger reducing the heat losses from ventilation. The ambient air heat and moisture are transferred to the exhaust air stream through the enthalpy heat exchanger in the warm season.

This allows for a considerable reduction of the supply air temperature and humidity which, in turn, reduces the air conditioning load.

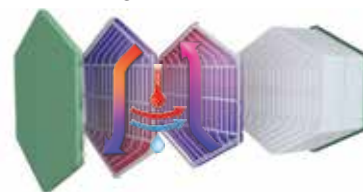

■ **Bypass**

The **RECOM S/SE/SF/SEF EC** units are equipped with a by-pass for summer ventilation (air cooling by the cool air from outside).

■ **Automation**

The **RECOM S/SE/SF/SEF EC** are equipped with a built-in automation system. The remote control panel is not included in the delivery set (available separately). To control the unit via Wi-Fi, download the RECOM AHU - Play Market mobile app.



■ **Freeze protection**

Freeze protection is provided by the shutdown of the supply fan. In the **RECOM S/SE/SF/SEF EC** units it is possible to connect a preheater to protect the unit from freezing.

Designation key

Series	Rated air flow [m ³ /h]	Installation features	Casing design	Bypass	Motor type
RECOM S/SF: ventilation with heat recovery	160, 200, 250, 300, 350,	Vertical	2S2: casing modification	With bypass	EC: synchronous electronically commutated motor
RECOM SE/SEF: ventilation with energy recovery	550				

Control and automation

Functions	RECOM S/SE/SF/SEF EC
Wired remote control panel	Option (FP) 
Wired remote LCD control panel	Option (FPD) 
Wireless remote control panel	Option (FP Wi-Fi) 
BMS	RS-485 Wi-Fi Ethernet MODBUS (RTU, TCP)
Service Vents Cloud Server	+
Control by a mobile application via Wi-Fi	+
Freeze protection	+
Bypass	Auto + manual
Week-scheduled operation	+
Filter replacement indication	According to filter timer According to pressure switch of filter clogging (only for RECOM 6 S/SE EC)
Alarm indication	+
Speed selection	+
Timers	+
RH% sensor	Option
CO ₂ sensor	Option
VOC sensor	Option
PM2.5 sensor	Option
Boost mode	+
Fireplace mode	+
Preheater connection	Option (built-in preheater in RECOM 6 S/SE EC units)
Reheater connection	Option
Cooler connection	Option
Fire alarm sensor	Option
Minimum supply air temperature control	+

Installation

The units are designed for wall or floor mounting. Access for maintenance of units and filters is possible from the right and left side.

Unit design

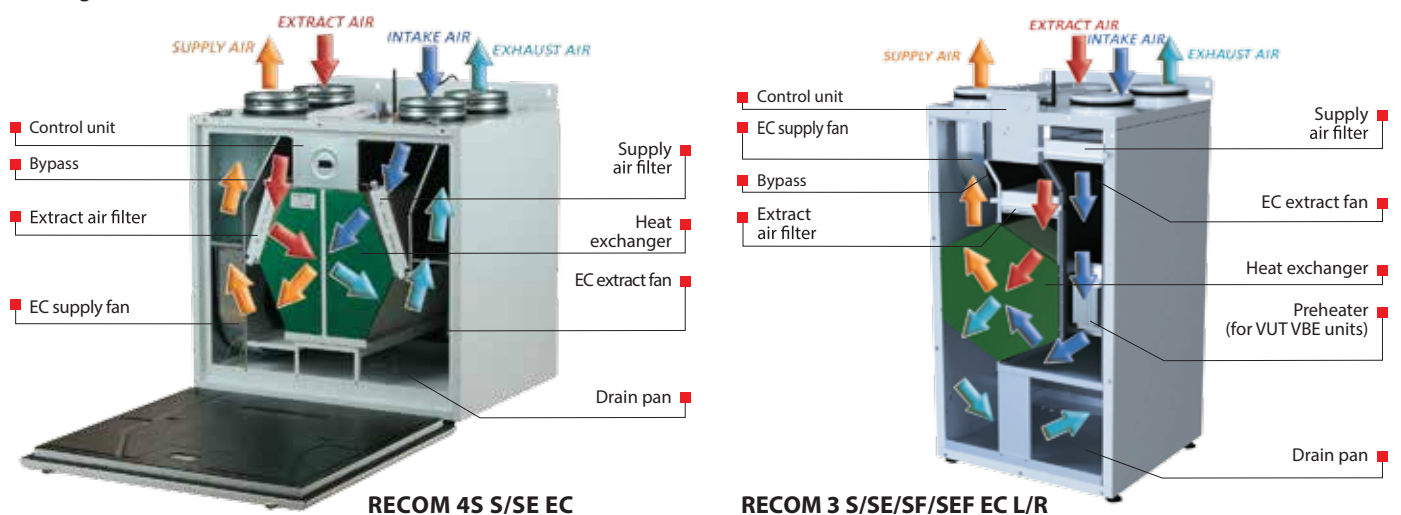

AIR HANDLING UNITS WITH HEAT RECOVERY

Technical data

	RECOM 2S2 EC	RECOM 2SE2 EC	RECOM 2 S EC	RECOM 2 SE EC
Unit voltage [V/50 (60) Hz]	1~230			
Maximum power [W]	57			
Maximum current [A]	0.5			
Maximum air flow [m ³ /h]	200			
RPM [min ⁻¹]	3770			
Sound pressure level at 3 m distance [dBA]	24		22	
Transported air temperature [°C]	from -25 up to +40			
Casing material	painted steel			
Insulation	20 mineral wool		40 mineral wool	
Extract filter	G4			
Supply filter	F7 (optionally G4)			
Connected air duct diameter [mm]	Ø125			
Weight [kg]	36		44	
Heat recovery efficiency [%]	from 85 up to 93	from 76 up to 92	from 85 up to 93	from 76 up to 92
Heat exchanger type	counter-flow			
Heat exchanger material	polystyrene	enthalpy	polystyrene	enthalpy
Energy efficiency class	A+	A	A+	A

RECOM S/SE EC

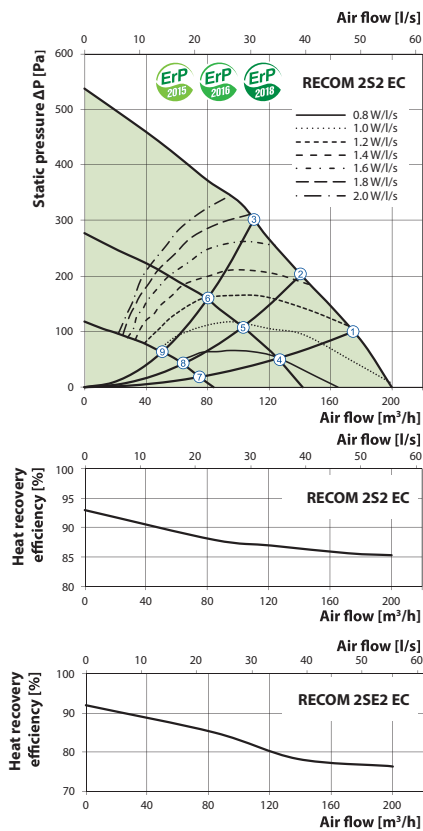

RECOM 2S2, RECOM 2SE2 EC

A-weighted sound power level	Gen. dBA	Octave frequency band [Hz]								LpA, 3 m dBA	LpA, 1 m dBA	
		63	125	250	500	1000	2000	4000	8000			
L _{WA} to supply air inlet	dBA	52	28	46	49	41	35	33	36	29		
L _{WA} to supply air outlet	dBA	60	32	52	58	47	37	36	41	35		
L _{WA} to exhaust air inlet	dBA	51	27	45	49	41	36	32	35	29		
L _{WA} to exhaust air outlet	dBA	60	31	50	59	48	36	36	41	32		
L _{WA} to environment	dBA	45	25	41	42	34	31	28	27	22	24	34

AIR HANDLING UNITS WITH HEAT RECOVERY

Technical data

	RECOM 3SF EC L/R	RECOM 3SEF EC L/R
Unit voltage [V/50 (60) Hz]	1~230	
Maximum power [W]	180	
Maximum current [A]	1,37	
Electric heater power [W]	1400	
Electric heater current [A]	6,09	
Maximum unit power with an electric heater [W]	1580	
Maximum unit power (with an electric heater) [A]	7,46	
Maximum air flow [m ³ /h]	390	
RPM [min ⁻¹]	2600	
Sound pressure level at 3 m distance [dBA]	35	
Transported air temperature	-25...+40	
Casing material	painted steel	
Insulation	30 mm mineral wool	
Extract filter	G4	
Supply filter	G4 (F7 - option)	
Connected air duct diameter [mm]	Ø160	
Weight	66	
Heat recovery efficiency [%]	88-95	78-90
Heat exchanger type	counter-flow	
Heat exchanger material	polysterene	enthalpy
Energy efficiency class	A+	A

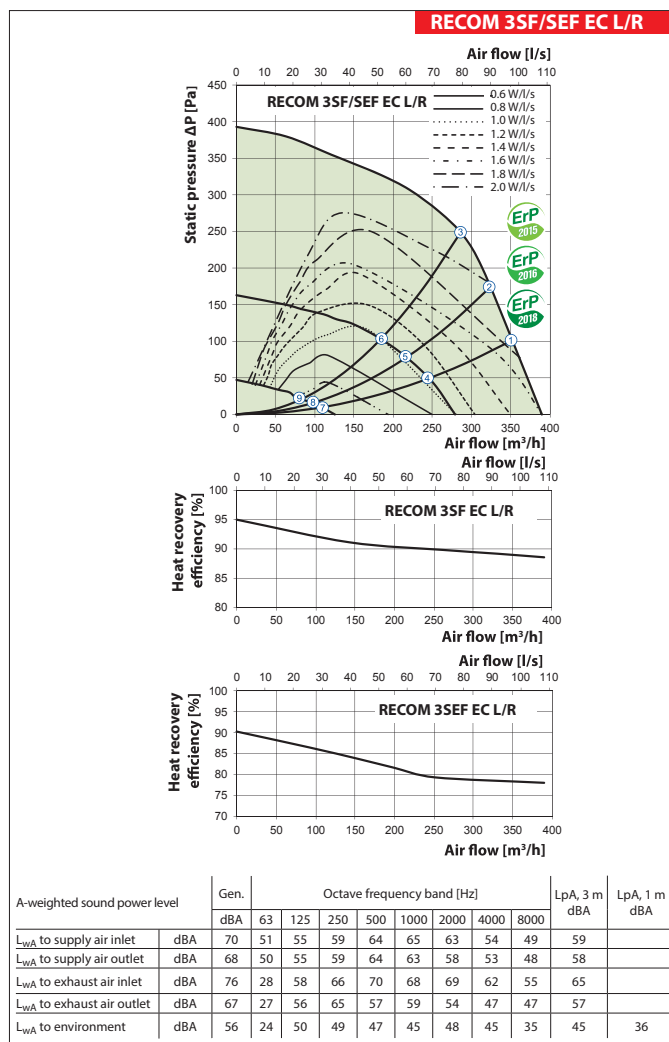

AIR HANDLING UNITS WITH HEAT RECOVERY

Technical data

	RECOM 4 S EC	RECOM 4SE EC
Unit voltage [V/50 (60) Hz]	1~230	
Maximum power [W]	178	
Maximum current [A]	1.4	
Maximum air flow [m ³ /h]	450	
RPM [min ⁻¹]	3200	
Sound pressure level at 3 m distance [dBA]	28	
Transported air temperature [°C]	from -25 up to +40	
Casing material	painted steel	
Insulation	40 mineral wool	
Extract filter	G4	
Supply filter	F7 (optionally G4)	
Connected air duct diameter [mm]	Ø160	
Weight [kg]	64	
Heat recovery efficiency [%]	from 85 up to 92	from 73 up to 91
Heat exchanger type	counter-flow	
Heat exchanger material	polystyrene	enthalpy
Energy efficiency class	A+	A

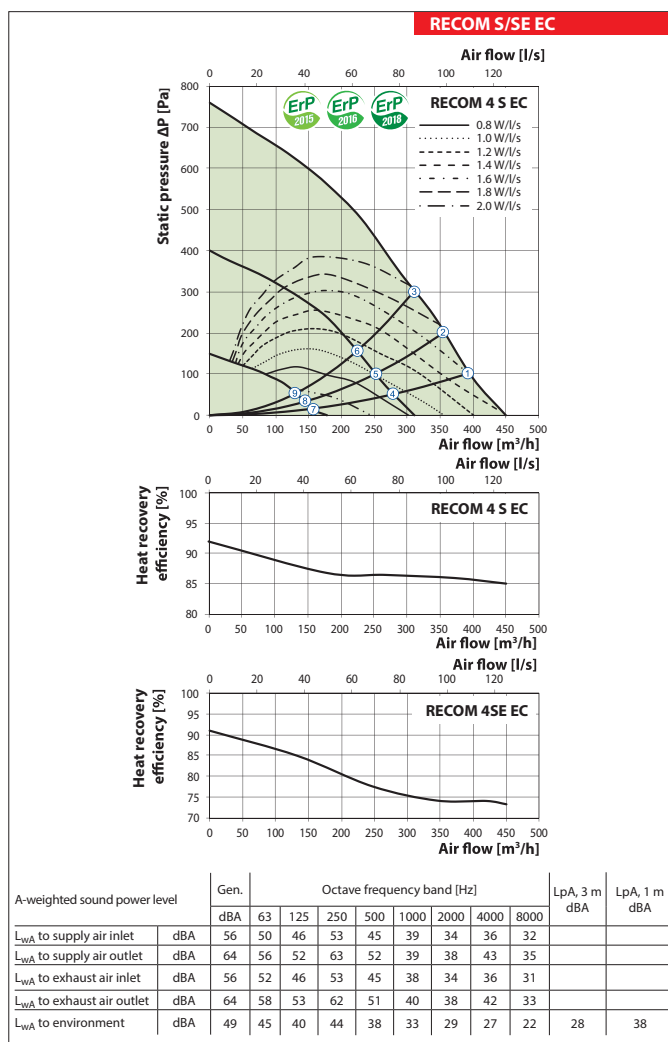

Technical data

	RECOM 6 S EC	RECOM 6 SE EC
Unit voltage [V/50 (60) Hz]	1~230	
Maximum power [W]	337	
Maximum current [A]	2.4	
Maximum air flow [m ³ /h]	690	
RPM [min ⁻¹]	2860	
Sound pressure level at 3 m distance [dBA]	26	
Transported air temperature [°C]	from -25 up to +40	
Casing material	painted steel	
Insulation	40 mineral wool	
Extract filter	G4	
Supply filter	F7 (optionally G4)	
Connected air duct diameter [mm]	Ø200	
Weight [kg]	82	
Heat recovery efficiency [%]	from 84 up to 92	from 73 up to 91
Heat exchanger type	counter-flow	
Heat exchanger material	polystyrene	enthalpy
Energy efficiency class	A+	A

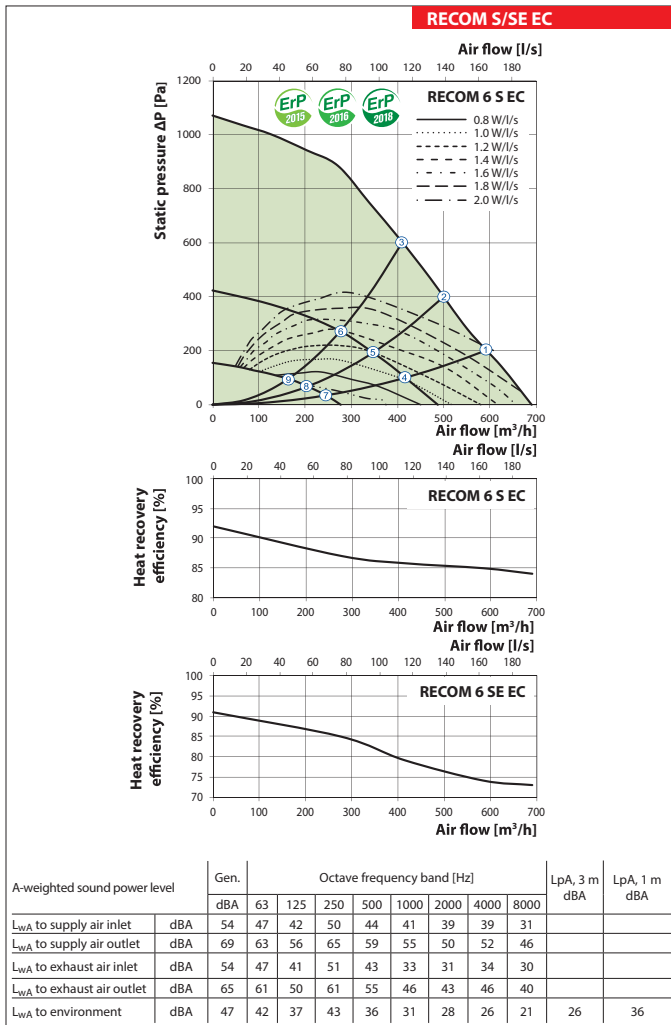

Calculation of air temperature downstream of the heat exchanger:

$$t_{\text{outd}} = t_{\text{extr}} + k_{\text{hr}} * (t_{\text{extr}} - t_{\text{outd}}) / 100,$$

where

t_{outd} – outdoor air temperature [°C]

t_{extr} – extract air temperature [°C]

k_{hr} – heat exchanger efficiency (according to the diagram) [%]

AIR HANDLING UNITS WITH HEAT RECOVERY

Point	Power [W]			
	RECOM 2S2 EC RECOM 2S EC RECOM 2SE2 EC RECOM 2SE EC	RECOM 3SF EC L/R RECOM 3SEF EC L/R	RECOM 4S EC RECOM 4SE EC	RECOM 6S EC RECOM 6SE EC
1	50	180	168	332
2	51	179	167	331
3	50	168	165	332
4	22	63	101	133
5	22	57	99	129
6	21	52	97	126
7	9	15	27	32
8	9	15	27	31
9	9	14	26	30







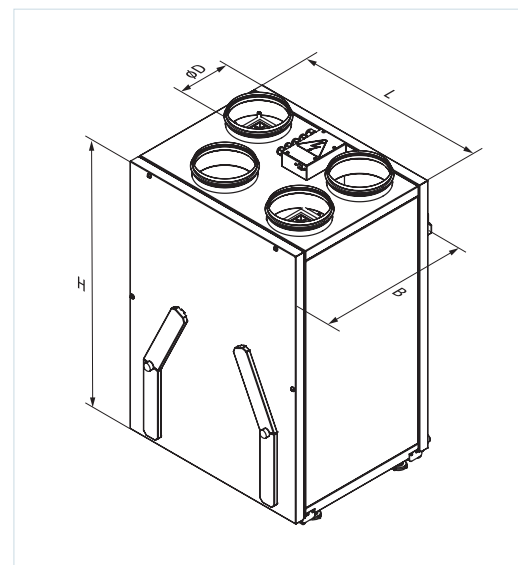

Point	Sound pressure level at 3 m distance [dBA]			
	RECOM 2S2 EC RECOM 2S EC RECOM 2SE2 EC RECOM 2SE EC	RECOM 3SF EC L/R RECOM 3SEF EC L/R	RECOM 4S EC RECOM 4SE EC	RECOM 6S EC RECOM 6SE EC
1	24 (34)	35 (45)	28 (38)	26 (36)
2	23 (33)	35 (45)	27 (37)	26 (36)
3	23 (33)	35 (45)	27 (37)	25 (35)
4	20 (30)	24 (34)	23 (33)	25 (35)
5	20 (30)	24 (34)	22 (32)	24 (34)
6	20 (30)	23 (33)	22 (32)	22 (32)
7	13 (23)	18 (27)	15 (25)	15 (25)
8	13 (23)	17 (27)	14 (24)	14 (24)
9	13 (23)	17 (27)	14 (24)	13 (23)





Overall dimensions

Model	Dimensions [mm]			
	Ø D	B	H	L
RECOM 2S2/2SE2 EC	124	330	580	600
RECOM 2S/2SE EC	124	370	620	640
RECOM 3SF/SEF EC L/R	160	560	970	560
RECOM 4S/4SE EC	159	475	673	730
RECOM 6S/6SE EC	198	722	675	828



Accessories for air handling units

Model	Panel filter G4	Panel filter F7	LCD control panel	Control panel	Control panel with Wi-Fi	Indoor humidity sensor	CO ₂ sensor with indication	CO ₂ sensor
								
RECOM 2S2 EC			FPD	FP	FP Wi-Fi			
RECOM 2SE2 EC	SF 285x195x10 G4	SF 285x195x10 F7	FPD	FP	FP Wi-Fi			
RECOM 2S EC			FPD	FP	FP Wi-Fi			
RECOM 2SE EC			FPD	FP	FP Wi-Fi			
RECOM 3SF EC L/R	SF 500x170x48 G4	SF 340x170x48 F7	FPD	FP	FP Wi-Fi	HS	+	HS
RECOM 3SEF EC L/R			FPD	FP	FP Wi-Fi			
RECOM 4S EC	SF 384x196x40 G4	SF 384x196x40 F7	FPD	FP	FP Wi-Fi			
RECOM 4SE EC			FPD	FP	FP Wi-Fi			
RECOM 6S EC	SF 630x198x40 G4	SF 630x198x40 F7	FPD	FP	FP Wi-Fi			
RECOM 6SE EC			FPD	FP	FP Wi-Fi			

Model	VOC sensor (0-10 V)	CO ₂ sensor (0-10 V)	Humidity sensor (0-10 V)	Kitchen hood	Electric heater for preheating	Electric reheater
						
RECOM 2S2 EC	+	+	+	SR	FVB 125-0,6-1	EVB 125-0,6-1
RECOM 2SE2 EC	+	+	+		FVB 125-0,6-1	EVB 125-0,6-1
RECOM 2S EC	+	+	+		FVB 125-0,6-1	EVB 125-0,6-1
RECOM 2SE EC	+	+	+		FVB 125-0,6-1	EVB 125-0,6-1
RECOM 3SF EC L/R	+	+	+		FVB 160-1,0-1	EVB 160-1,0-1
RECOM 3SEF EC L/R	+	+	+		FVB 160-1,0-1	EVB 160-1,0-1
RECOM 4S EC	+	+	+		FVB 160-1,0-1	EVB 160-1,0-1
RECOM 4SE EC	+	+	+		FVB 160-1,0-1	EVB 160-1,0-1
RECOM 6S EC	+	+	+		FVB 200-1,8-1	EVB 200-1,8-1
RECOM 6SE EC	+	+	+		FVB 200-1,8-1	EVB 200-1,8-1

RIGHT-HANDED AND LEFT-HANDED MODIFICATIONS

The figure below shows the arrangement of spigots for left- and right-handed modifications. Choosing the right arrangement can improve the ease of installation, shorten the length of the ducts and reduce the number of air duct bends.

RECOM 3 S(E)(F) EC-L

RECOM 3 S(E)(F) EC-R

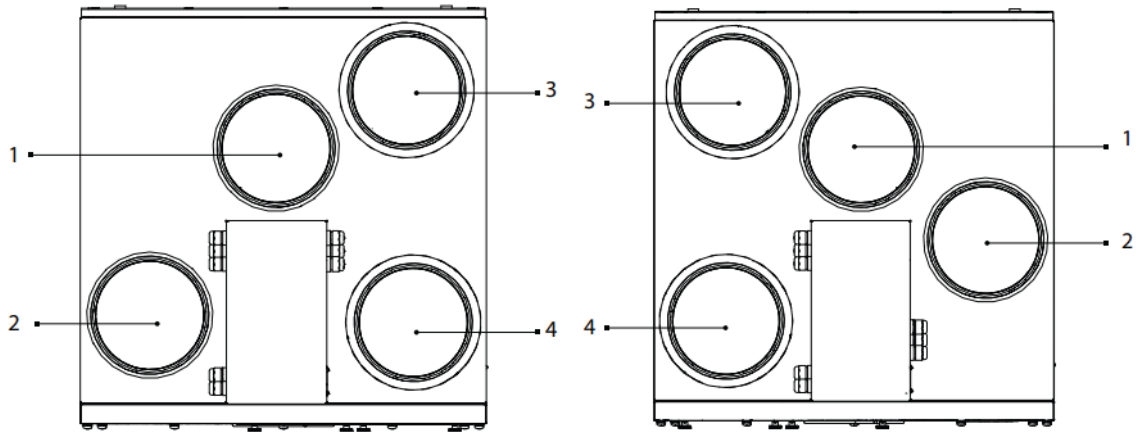

1 – extract air 2 – supply air 3 – exhaust air 4 – intake air

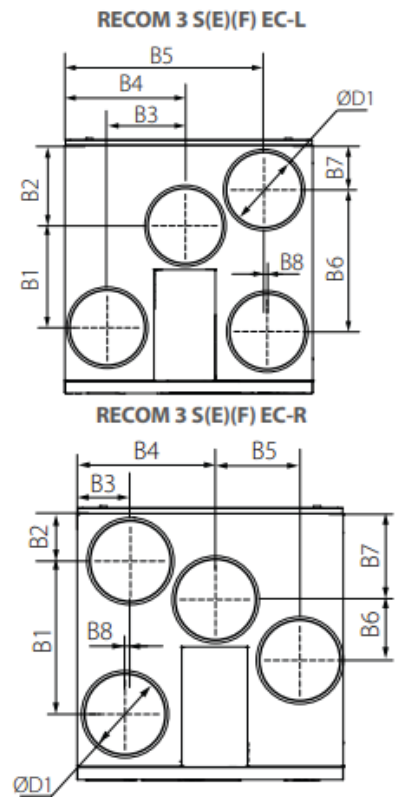
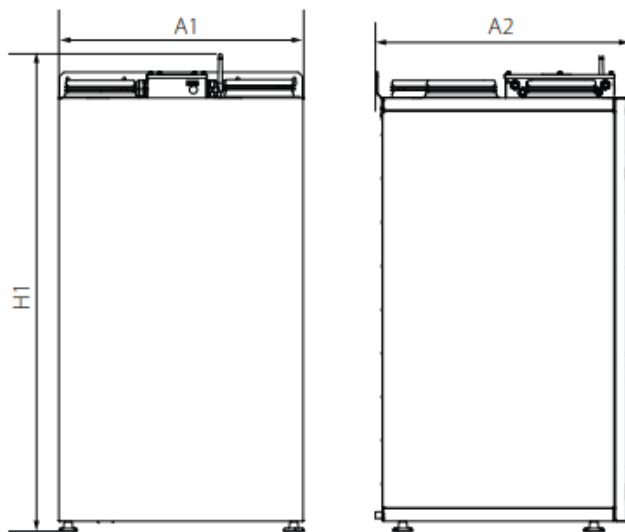

Model	Dimensions [mm]											
	H1	A1	A2	B1	B2	B3	B4	B5	B6	B7	B8	D1
RECOM 3 S(E)(F) EC-L	1094	560	583	230	181	174	270	450	320	101	9	160
RECOM 3 S(E)(F) EC-R				320	101	110	290	174	127	181	9	

OVERALL DIMENSIONS OF UNITS [MM]

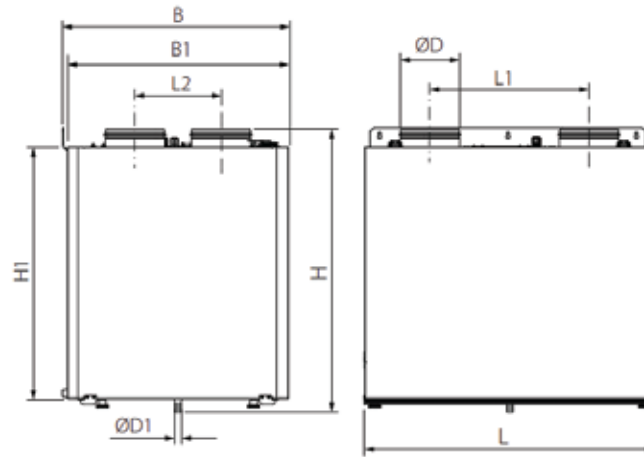

Model	Dimensions [mm]								
	Ø D	Ø D1	B	B1	H	H1	L	L1	L2
RECOM 2 S/SE EC	125	18	340	330	665	580	600	388	143
RECOM 4 S/SE EC	160	18	600	583	760	675	730	426	230
RECOM 6 S/SE EC	200	18	730	720	760	675	823	498	288