

USER'S MANUAL

RECOM 3 S EC-L
RECOM 3 S EC-R
RECOM 3 SE EC-L
RECOM 3 SE EC-R

RECOM 3 SF EC-L
RECOM 3 SF EC-R
RECOM 3 SEF EC-L
RECOM 3 SEF EC-R

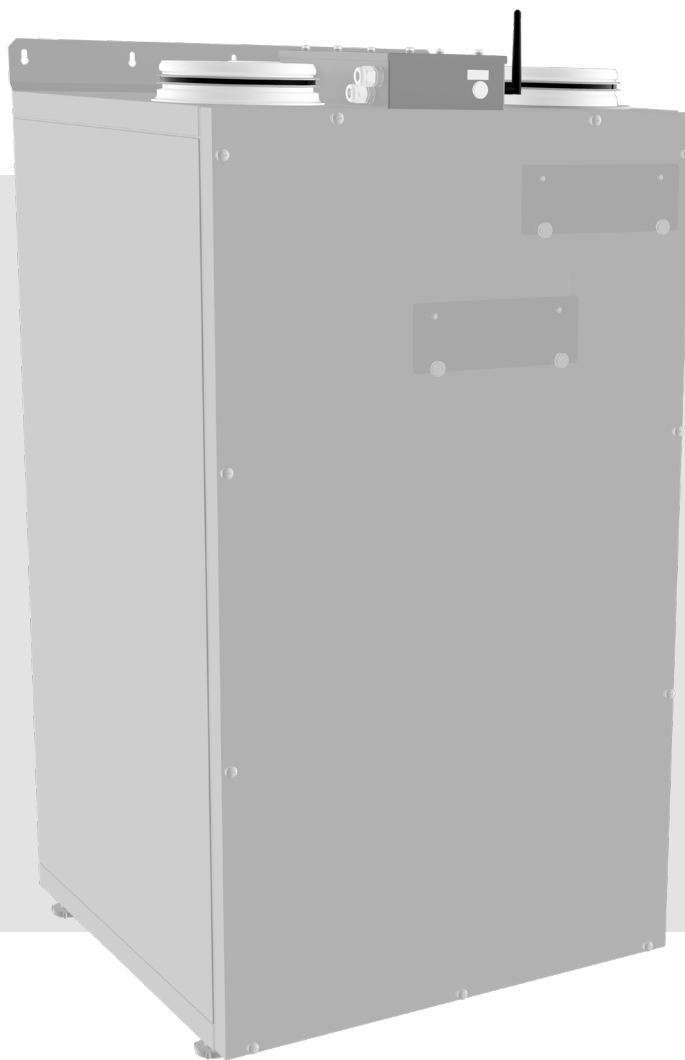

Air handling unit

CONTENTS

Safety requirements.....	2
Purpose.....	4
Delivery set.....	4
Technical data.....	5
Design and operating principle	7
Mounting and set-up.....	9
Connection to power mains	11
Technical maintenance.....	13
Troubleshooting.....	15
Storage and transportation regulations.....	16
Manufacturer's warranty.....	17
Certificate of acceptance.....	19
Seller information.....	19
Installation certificate.....	19
Warranty card.....	19

This user's manual is a main operating document intended for technical, maintenance, and operating staff.

The manual contains information about purpose, technical details, operating principle, design, and installation of the RECOM 3 S(E)(F) EC-L/R unit and all its modifications.

Technical and maintenance staff must have theoretical and practical training in the field of ventilation systems and should be able to work in accordance with workplace safety rules as well as construction norms and standards applicable in the territory of the country.

SAFETY REQUIREMENTS

All user's manual requirements as well as the provisions of all the applicable local and national construction, electrical, and technical norms and standards must be observed when installing and operating the unit.

Disconnect the unit from the power supply prior to any connection, servicing, maintenance, and repair operations.

Only qualified electricians with a work permit for electrical units up to 1000 V are allowed for installation. The present user's manual should be carefully read before beginning works.

Check the unit for any visible damage of the impeller, the casing, and the grille before starting installation. The casing internals must be free of any foreign objects that can damage the impeller blades.

While mounting the unit, avoid compression of the casing! Deformation of the casing may result in motor jam and excessive noise.

Misuse of the unit and any unauthorised modifications are not allowed.

Do not expose the unit to adverse atmospheric agents (rain, sun, etc.).

Transported air must not contain any dust or other solid impurities, sticky substances, or fibrous materials.

Do not use the unit in a hazardous or explosive environment containing spirits, gasoline, insecticides, etc.

Do not close or block the intake or extract vents in order to ensure the efficient air flow.

Do not sit on the unit and do not put objects on it.

The information in this user's manual was correct at the time of the document's preparation.

The Company reserves the right to modify the technical characteristics, design, or configuration of its products at any time in order to incorporate the latest technological developments.

Never touch the unit with wet or damp hands.
Never touch the unit when barefoot.

This unit is not intended for use by persons (including children) with reduced physical, sensory or mental capabilities, or lack of experience and knowledge, unless they have been given supervision or instruction concerning use of the unit by a person responsible for their safety. Children should be supervised to ensure that they do not play with the unit.

If the supply cord is damaged, it must be replaced by the manufacturer, its service agent, or similarly qualified persons in order to avoid a safety hazard.

Precautions must be taken to avoid the back-flow of gases into the room from the open flue of gas or other fuel-burning appliances.

Ensure that the unit is switched off from the supply mains before removing the guard.



**THE PRODUCT MUST BE DISPOSED SEPARATELY AT THE END OF ITS SERVICE LIFE.
DO NOT DISPOSE THE UNIT AS UNSORTED DOMESTIC WASTE.**

PURPOSE

The unit is designed to ensure continuous mechanical air exchange in offices, hotels, cafés, conference halls, and other public spaces as well as to recover the heat energy contained in the air extracted from the premises to warm up the filtered stream of supply air.

The unit is not intended for organizing ventilation in swimming pools, saunas, greenhouses, summer gardens, and other spaces with high humidity.

Due to the ability to save heating energy by means of energy recovery, the unit is an important element of energy-efficient premises.

The unit is a component part and is not designed for stand-alone operation. It is rated for continuous operation.

Transported air must not contain any flammable or explosive mixtures, evaporation of chemicals, sticky substances, fibrous materials, coarse dust, soot and oil particles or environments favourable for the formation of hazardous substances (toxic substances, dust, pathogenic germs).

DELIVERY SET

Name	Number
Air handling unit	1
User's manual	1
Control panel*	1
Packing box	1

*The control panel is not included in the delivery set of the units with the RECOM controller.

TECHNICAL DATA

The unit is designed for indoor application with the ambient temperature ranging from +1 °C up to +40 °C and relative humidity up to 60 % without condensation. In cold, damp rooms, there is a possibility of freezing or condensation inside and outside the casing.

In order to prevent condensation on the internal walls of the unit, it is necessary that the surface temperature of the casing is 2-3 °C above the dew point temperature of the transported air.

The unit should be operated continuously, and in cases where ventilation is not necessary, reduce the air flow of the fans to a minimum (20%). This will ensure a favorable indoor climate and reduce the amount of condensation inside the unit, which can damage electronic components. Never use the unit for dehumidification, for example, of new buildings.

The unit is rated as a Class I electrical appliance.

Hazardous parts access and water ingress protection rating:

IP20 for the unit connected to the air ducts

IP44 for the unit motors

The unit design is constantly being improved, thus some models may be slightly different from those described in this manual.

MODEL	RECOM 3 S EC-L/R	RECOM 3 SE EC-L/R	RECOM 3 SF EC-L/R	RECOM 3 SEF EC-L/R
Supply voltage, 50 (60) Hz [V]	1~ 230			
Maximum fan power [W]	180			
Maximum unit current (without a heater) [A]	1.35			
Maximum electric heater power [W]	—		1400	
Maximum electric heater current [A]	—		6.09	
Maximum air flow [m ³ /h]	390			
RPM [min ⁻¹]	2600			
Sound pressure level at 3 m distance [dBA]	35			
Transported air temperature [°C]	-25...+40			
Casing material	Painted steel			
Insulation, mineral wool [mm]	30			
Filtering class of the extract filter	G4			
Filtering class of the supply filter	G4 (optionally F7)			
Connected air duct diameter [mm]	160			
Weight [kg]	66			
Heat recovery efficiency [%]	88-95	78-90	88-95	78-90
Heat exchanger type	Counter-flow			
Heat exchanger material	Polystyrene	Enthalpy	Polystyrene	Enthalpy
SEC class	A+	A	A+	A

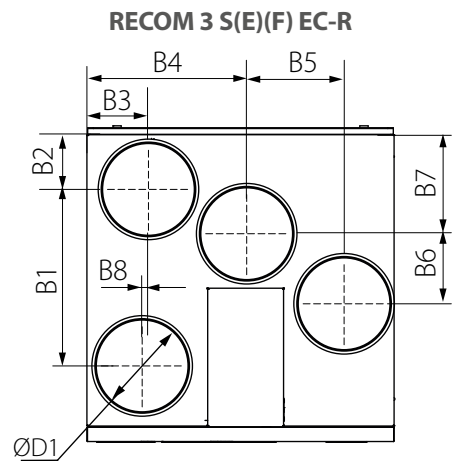
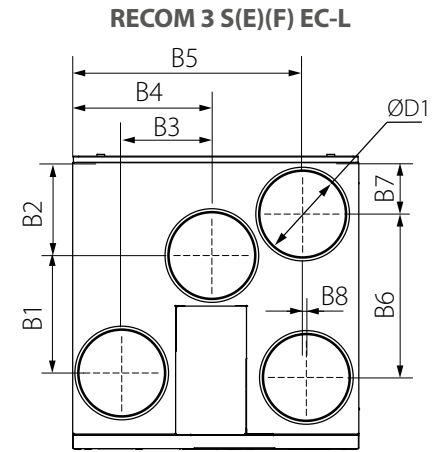
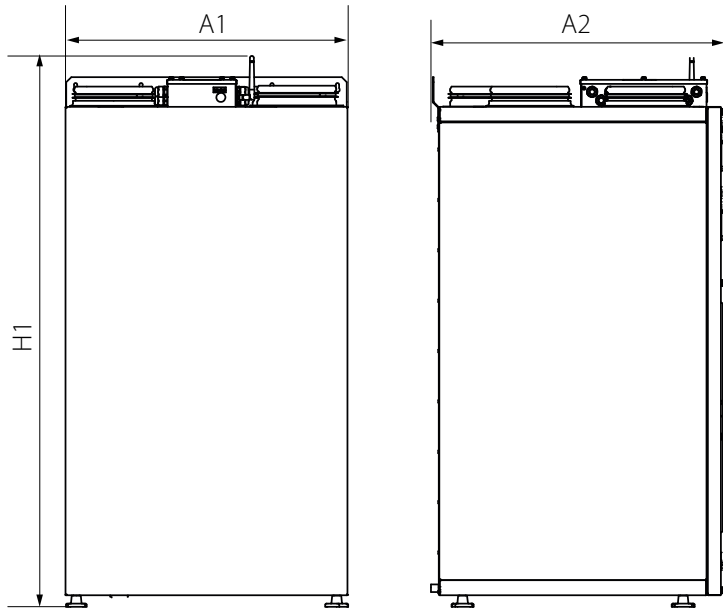

Model	Dimensions [mm]											
	H1	A1	A2	B1	B2	B3	B4	B5	B6	B7	B8	D1
RECOM 3 S(E)(F) EC-L	1094	560	583	230	181	174	270	450	320	101	9	160
RECOM 3 S(E)(F) EC-R				320	101	110	290	174	127	181	9	

DESIGN AND OPERATING PRINCIPLE

The unit has the following operating logic: warm stale extract air from the room flows into the unit, where it is filtered by the extract filter, then air flows through the heat exchanger and is exhausted outside by the exhaust fan. Cold fresh air from the outside flows into the unit, where it is cleaned by the supply filter. Then the air flows through the heat exchanger and is directed to the room with the supply fan. Heat energy of warm extract air is transferred to clean intake fresh air from the outside and warms it up. The air flows are fully separated while flowing through the heat exchanger. Heat recovery minimizes heat losses, which reduces the cost of space heating in the cold season.

UNIT DESIGN

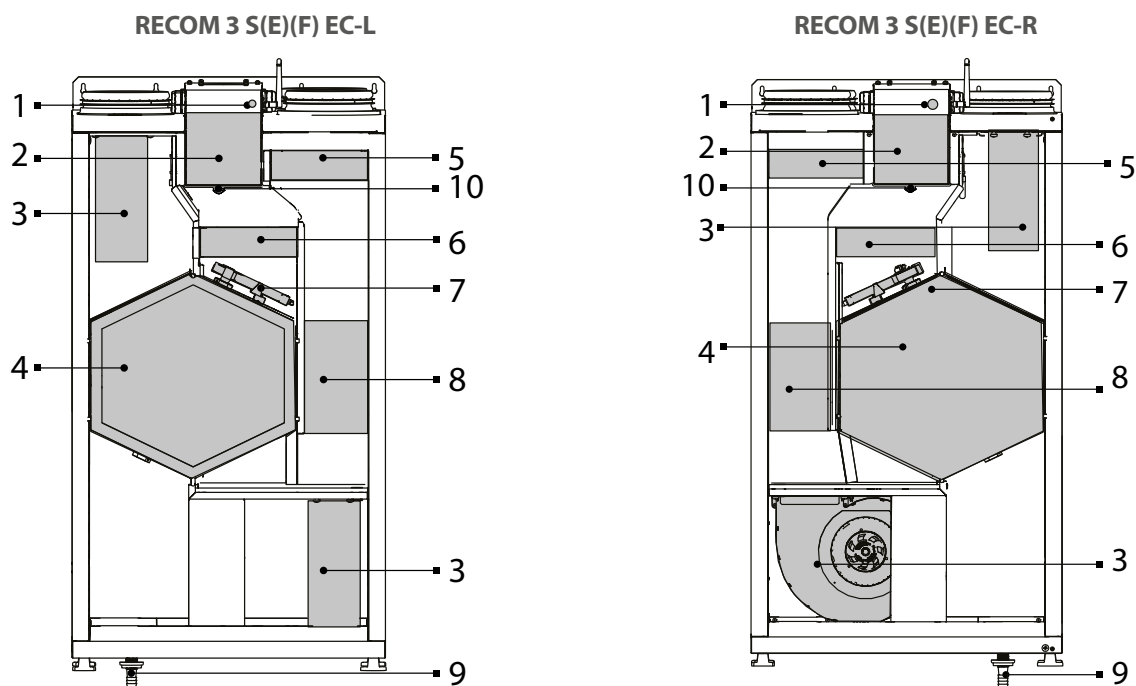

1 – SETUP MODE button (for the units with an RECOM automation) 2 – control unit 3 – fan unit 4 – counter-flow heat exchanger 5 – supply filter 6 – extract filter 7 – bypass damper 8 – electric heater (only for RECOM 3 SF EC-L/R units) 9 – drain pipe 10 – humidity sensor (optional)

The air handling unit is equipped with a front service panel for repair and maintenance operations. The control unit is accessible for installation and wiring operations through the inspection door on top of the unit. The power cable and ground cable are connected to the control unit via the electric lead-ins.

The bypass damper is open or closed depending on operation mode of the unit. During the operation of RECOM 3 S(F) EC-L/R units the difference between the supply and extract air flow temperature leads to condensate generation. Condensate is collected in the drain pan and is removed outside through the drain pipe. The RECOM 3 SE(F) EC-L/R units are equipped with an enthalpy heat exchanger and do not require condensate drainage.

Accessories for the unit are available on a separate order.

- **Humidity sensor.**

The unit with an installed humidity sensor maintains a set indoor humidity level. As the extract air humidity rises above the set point, the system automatically switches to the maximum speed. As the humidity drops down below the set point the unit returns to the previous mode.

- **CO₂ sensor** (connected to the controller).

Measures the level of concentration of carbon dioxide in the room and generates a signal that controls the performance of the fan. Air flow control based on CO₂ concentration is an efficient energy saving solution.

- **VOC sensor** (connected to the controller).

Qualitative assessment of air saturation with contaminants (cigarette smoke, exhaled air, solvent and detergent vapours). The sensor sensitivity can be adjusted with regards to the expected maximum level of air pollution. Enables on-demand ventilation which results in considerable energy savings as air is exchanged only upon reaching the preset level of pollution.

- **EVB duct heater for supply air reheating.**

The heater maintains the room temperature set by the user. Heater installation and connection to the unit are described in the heater user's manual.

RIGHT-HANDED AND LEFT-HANDED MODIFICATIONS

The figure below shows the arrangement of spigots for left- and right-handed modifications. Choosing the right arrangement can improve the ease of installation, shorten the length of the ducts and reduce the number of air duct bends.

RECOM 3 S(E)(F) EC-L

RECOM 3 S(E)(F) EC-R

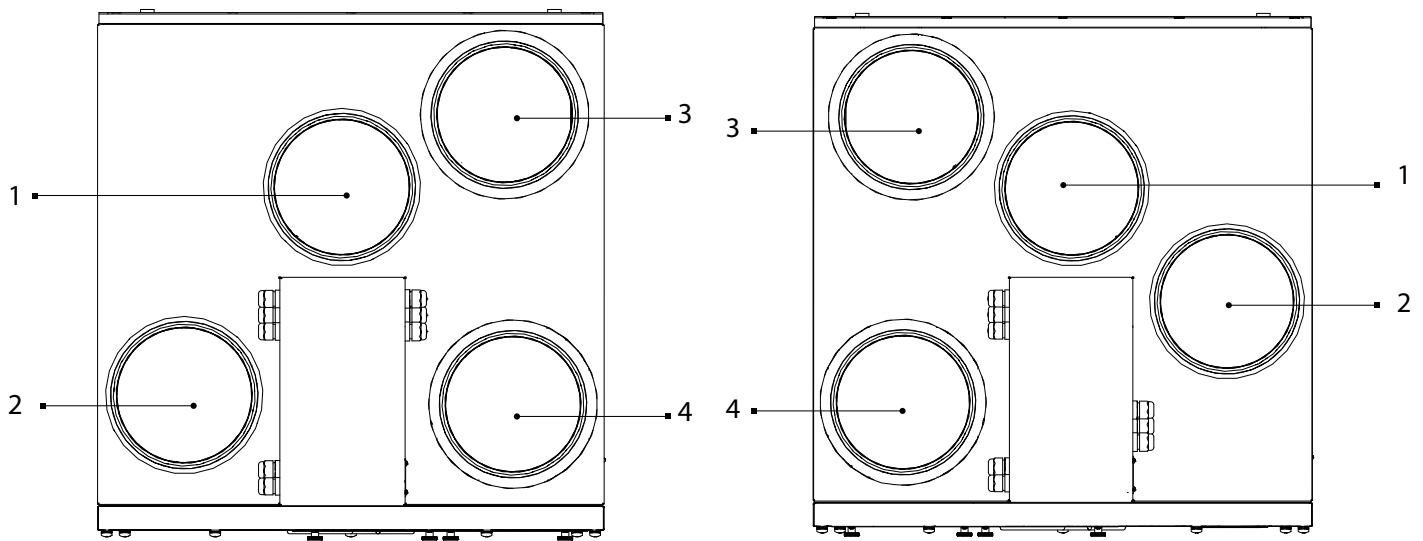

1 – extract air 2 – supply air 3 – exhaust air 4 – intake air

UNIT OPERATION LOGIC

Heat recovery

Air from the room flows into the unit, where it is filtered by the extract filter, then air flows through the heat exchanger and is exhausted outside by the exhaust fan. Air from outside flows into the unit, where it is cleaned in the intake filter. Then the air flows through the heat exchanger and is directed to the room with the supply fan. Supply air is heated in the heat exchanger by transferring the heat energy of warm and humid extract air to the cold fresh air. The air flows are fully separated while flowing through the heat exchanger. Heat recovery minimizes heat losses, which reduces the cost of space heating in the cold season.

Summer Cooling mode

The bypass damper is opened, the extract air that is removed from the premises bypasses the heat exchanger. The temperature of the air is not changed after passing through the heat exchanger.

Freeze protection

The unit has automatic heat exchanger freeze protection modes depending on the unit model. A freezing danger appears, if the exhaust air temperature downstream of the heat exchanger is below +5 °C and the intake air temperature upstream of the heat exchanger is below -3 °C.

There are two modes for freeze protection: switching off the supply fan and heating the air (only for RECOM 3 SF EC-L/R units). Mode selection and settings are described in the control system user's manual.

MOUNTING AND SET-UP**READ THE USER'S MANUAL BEFORE INSTALLING THE UNIT.**

To attain the best performance of the unit and to minimise turbulence-induced air pressure losses, connect the straight air duct section to the spigots on both sides of the unit while mounting.

Minimum straight air duct length:

- equal to 1 air duct diameter on the intake side
- equal to 3 air duct diameters on outlet side

If the air ducts are too short or not connected, protect the unit parts from ingress of foreign objects. To prevent uncontrollable access to the fans, the spigots may be covered with a protecting grille or other protecting device with mesh width not more than 12.5 mm. When choosing the unit installation location, it is necessary to provide free access to the hinged panel for technical and service maintenance.

The air ducts must be slipped over the unit flanges until tight. Flexible air ducts must be rigidly fixed with a metal worm clamp.

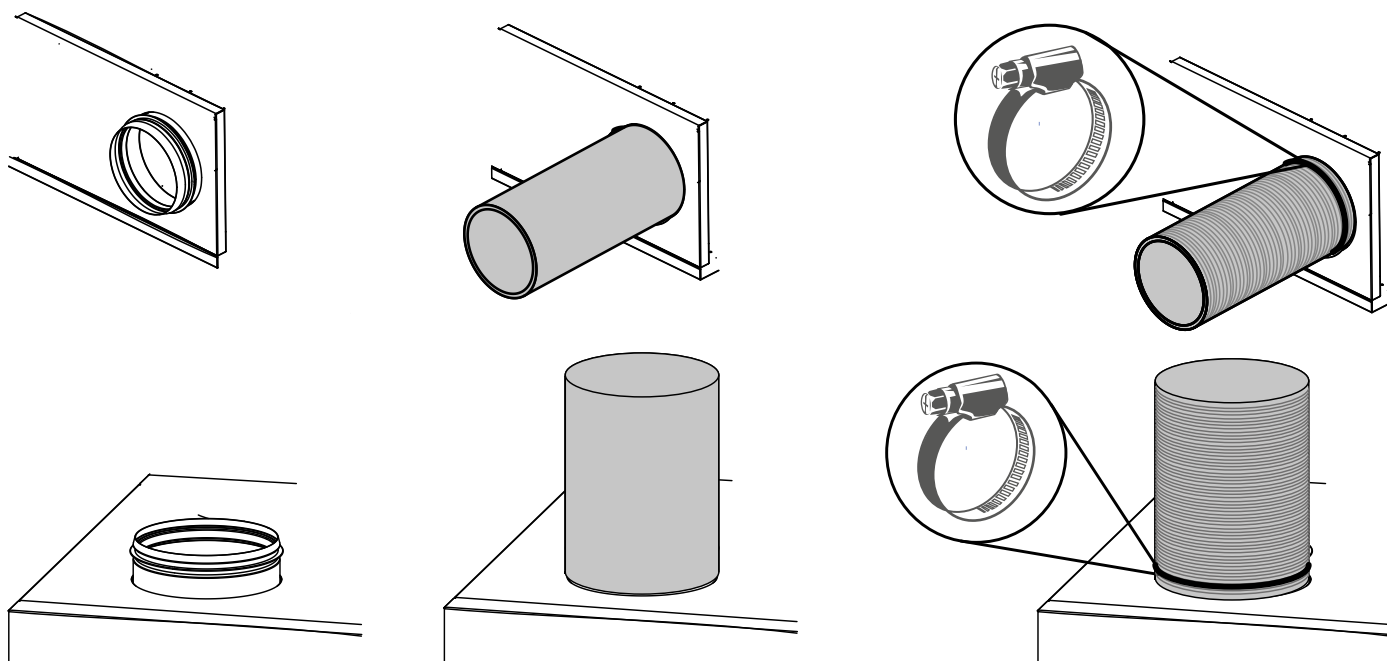

The unit must be mounted strictly horizontally in the longitudinal and transverse planes. Failure to do so will cause the unit casing distortion and may prevent proper operation.

Humidity sensor installation

The humidity sensor is not included in the delivery set and must be purchased separately. For ease of installation, it is recommended to remove the filter and the heat exchanger.

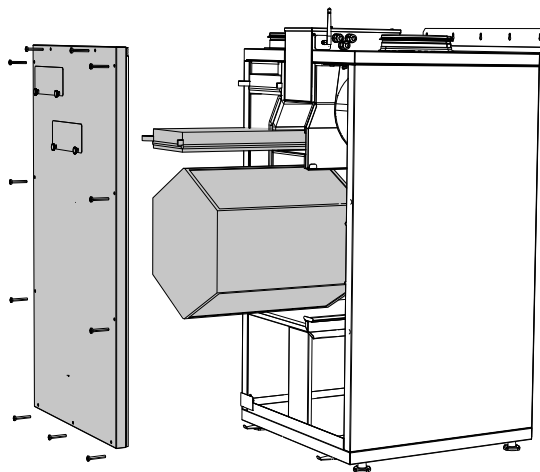

Connect the sensor connector to the connector with the cable from the control unit. Fasten the sensor with the screw on the threaded rivet.

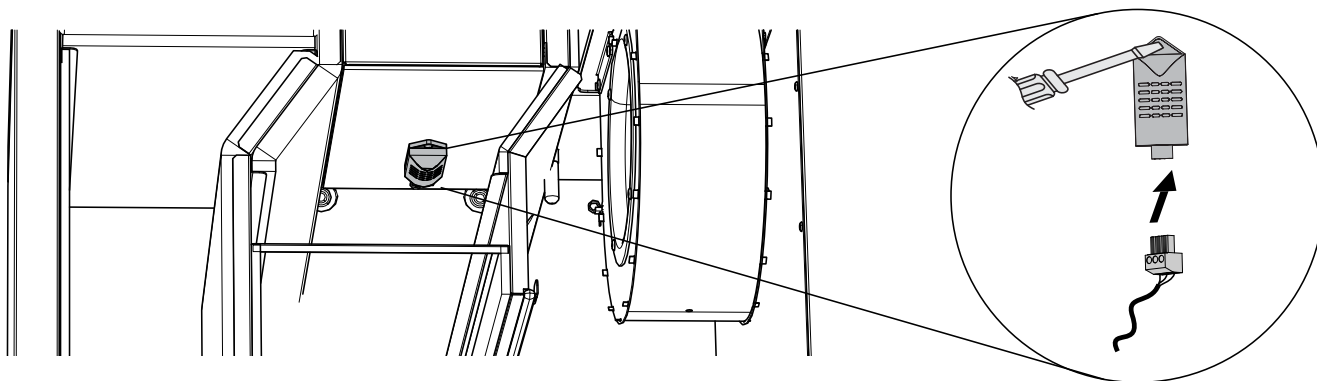

Unit floor mounting

Install the unit on the pre-mounted floor supports, minimum 150 mm height, to ensure sufficient access for the drain pipe connection to the U-trap and for condensate drain system installation.

Rotate the adjustable feet to achieve a strictly horizontal unit position.

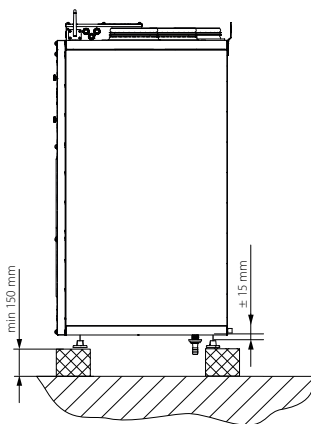

Unit wall mounting

Dowels for wall mounting are not included in the delivery set and should be ordered separately.

While choosing dowels consider the material of the mounting surface as well as the weight of the unit, refer to the "Technical data" section.

Dowels for unit mounting should be selected by a qualified specialist.

Insert the dowel into the wall.

The delivery set includes brackets for fixing the unit in earthquake-prone areas.

Install the mounting brackets on the wall.

Unscrew the feet.

Hang the unit and screw the feet through the holes in the brackets.

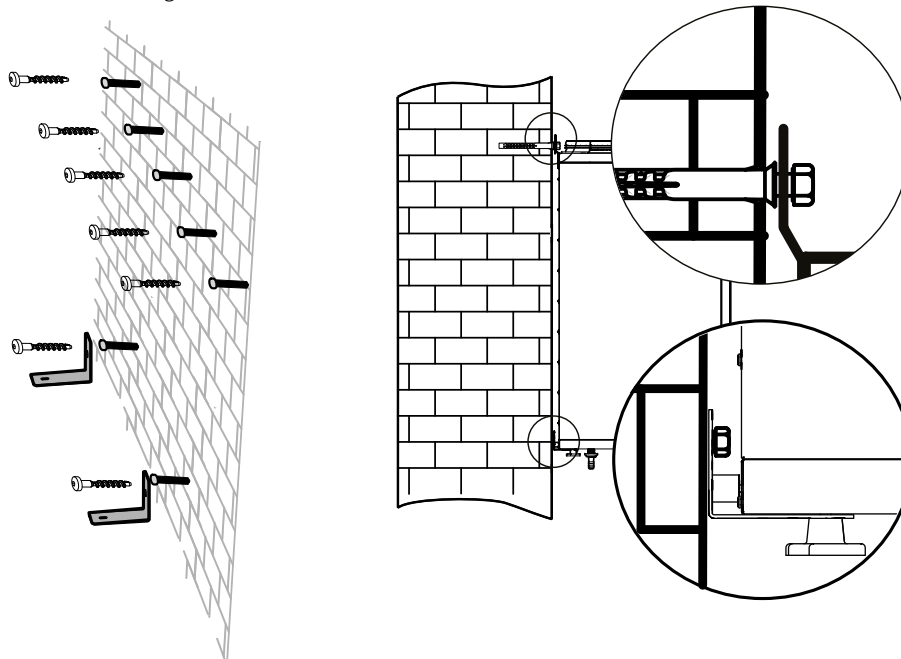

CONDENSATE DRAINAGE

Condensate drainage is required for the RECOM 3 S(F) EC-L/R unit series.

The hole for the drain pipe is at the bottom of the unit. Remove the plug from the hole in the unit. Install the drain pipe from the delivery set into the hole, then connect the drain pipe to the sewage system using the U-trap kit (available upon separate order). The U-trap must be constantly filled with water. The pipe slope downwards must be at least 3°.

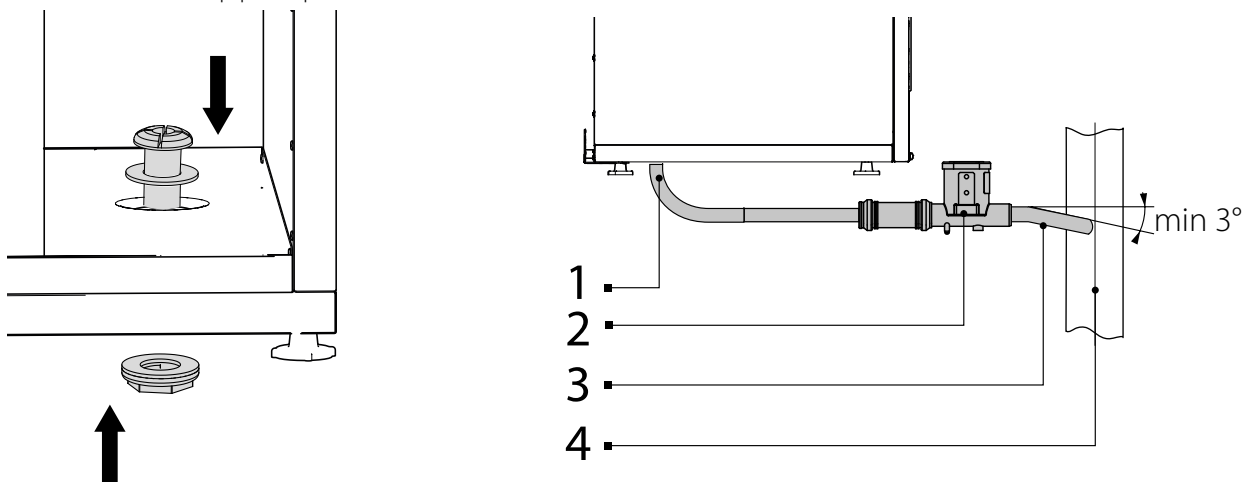

1 – drain pipe 2 – U-trap 3 – connecting pipe 4 – sewage system

CONNECTION TO POWER MAINS

**POWER OFF THE POWER SUPPLY PRIOR TO ANY OPERATIONS WITH THE UNIT.
THE UNIT MUST BE CONNECTED TO POWER SUPPLY BY A QUALIFIED ELECTRICIAN.
THE RATED ELECTRICAL PARAMETERS OF THE UNIT ARE GIVEN ON THE
MANUFACTURER'S LABEL.**



**ANY TAMPERING WITH THE INTERNAL CONNECTIONS IS PROHIBITED
AND WILL VOID THE WARRANTY.**

To access the control unit, remove the fixing screws and remove the cover. The control unit contains a terminal block and a controller for connecting external devices.

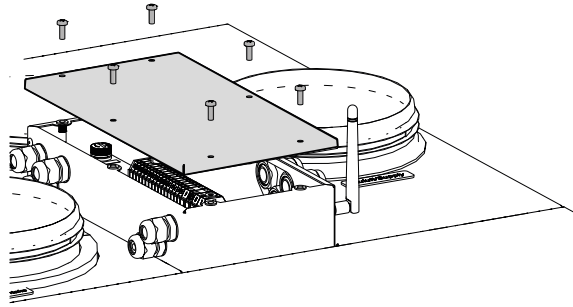

EXTERNAL CONNECTIONS DIAGRAM FOR THE RECOM 3 S(E)(F) EC-L/R FP

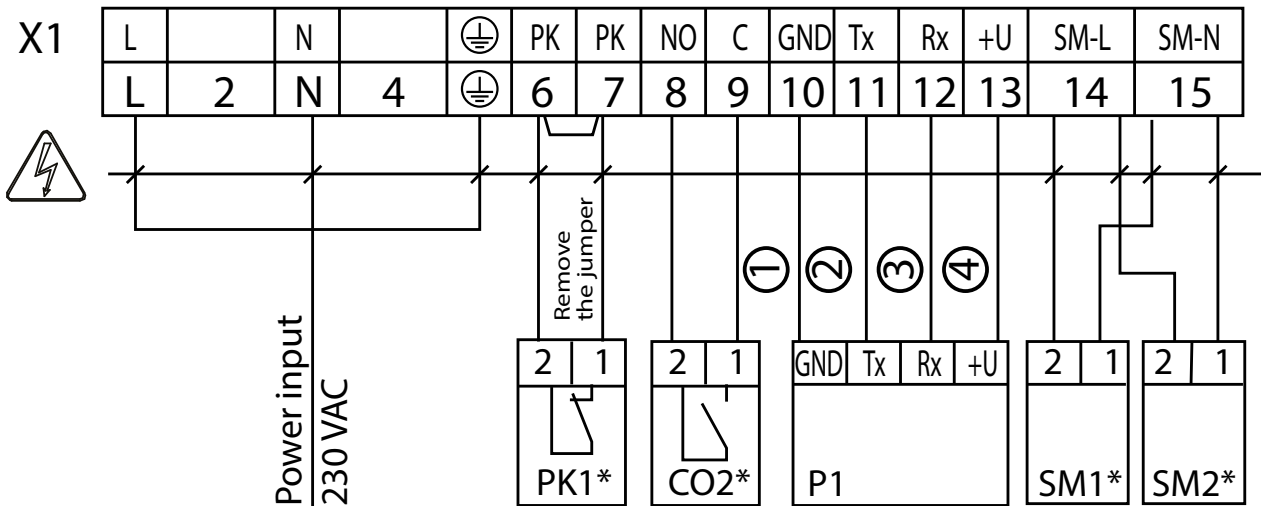

① — white; ② — brown; ③ — green; ④ — yellow.

Designation	Name	Wire	Model	Note
SM1*	Supply air damper actuator	2 x 0.75		
SM2*	Extract air damper actuator	2 x 0.75		
PK1*	Contact from fire alarm panel	2 x 0.75	NC	Remove the jumper
CO2*	CO ₂ sensor	2 x 0.75	NO	
P1	External control panel	4 x 0.25		

*Not included in the delivery set.



EXTERNAL CONNECTIONS DIAGRAM FOR THE RECOM 3 S(E)(F) EC-L/R FPD UNITS

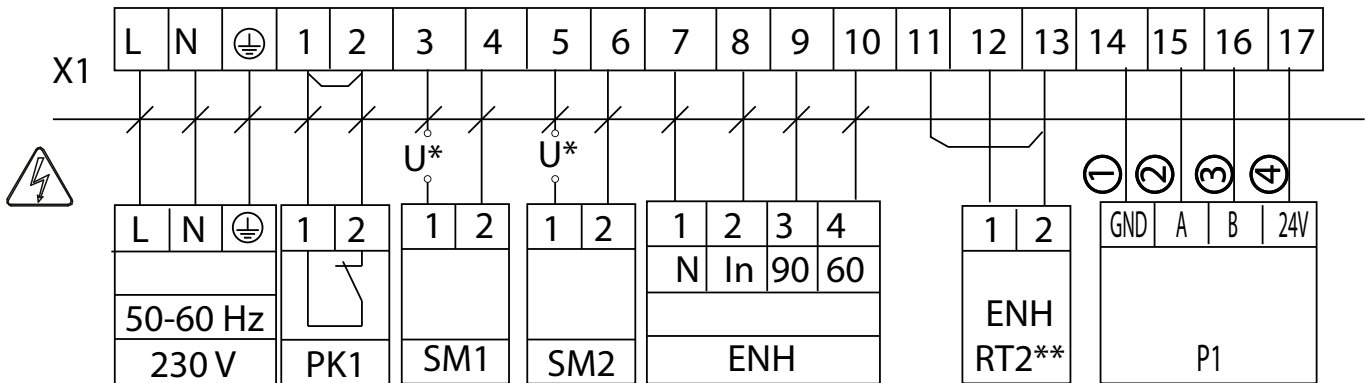

① — green; ② — brown; ③ — yellow; ④ — white.

Designation	Name	Cable type	Model	Note
SM1	Supply air damper actuator	2 x 0.75	NO	3 A, 30VDC/~250 AC
SM2	Exhaust air damper actuator	2 x 0.75	NO	3 A, 30VDC/~250 AC
PK1	Contact from fire alarm panel	2 x 0.75	NC	Remove the jumper
P1	External control panel	4 x 0.5		
ENH	Duct heater for reheating	4 x 0.5		
ENH RT2**	Duct temperature sensor	2 x 0.25		Remove the jumper

*The supply voltage of the SM1, SM2 external dampers is selected depending on the type of dampers.

**Part of ENH.



TECHNICAL MAINTENANCE



DISCONNECT THE UNIT FROM POWER SUPPLY BEFORE ANY MAINTENANCE OPERATIONS!
MAKE SURE THE UNIT IS DISCONNECTED FROM POWER MAINS BEFORE REMOVING THE PROTECTION

Maintenance operations of the unit are required 3-4 times per year. They include general cleaning of the unit and the following operations:

1. Filter maintenance (3-4 times per year).

Dirty filters increase air resistance in the system and reduce supply air volume. The filters require cleaning not less than 3-4 times per year. Clean the filter with a vacuum cleaner or replace it with a new one. For new filters contact the Seller. To access the filters, unscrew the thumbscrews and remove the service panels.

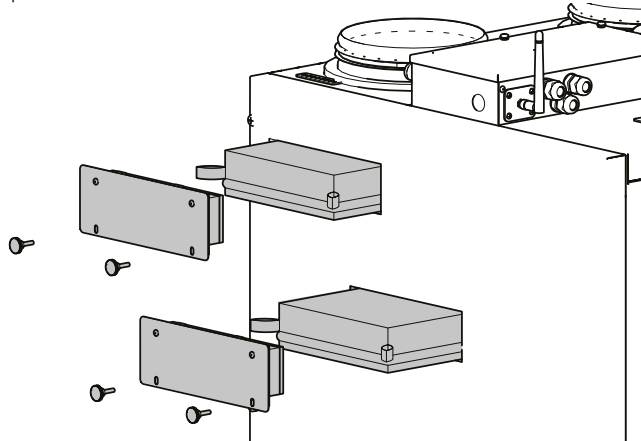

2. Heat exchanger maintenance (once per year).

Some dust may accumulate on the heat exchanger even in case of regular maintenance of the filters. To maintain high heat recovery efficiency, regular cleaning is required. To clean the heat exchanger, remove it from the unit and clean the heat exchanger by using compressed air or a vacuum cleaner. Remove the service panel and take it out of the unit for the heat exchanger service operations.

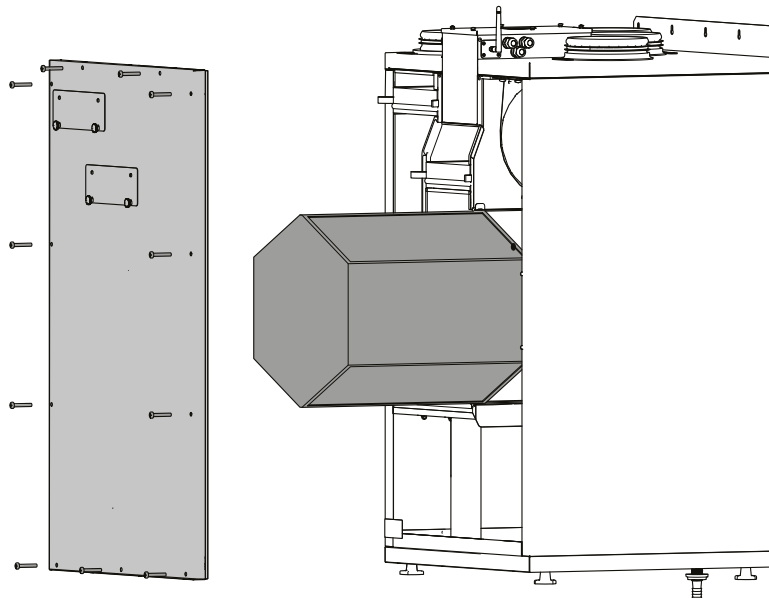

3. Fan maintenance (once per year).

Even in case of regular maintenance of the filters, some dust may accumulate inside the fans and reduce the fan performance and supply air flow. Fans should be cleaned selected by the service technician.

4. Condensate drainage system maintenance (4 times per year).

The condensate drainage (drain line) may get clogged by dirt and dust particles contained in the exhaust air. Check the drain line operation by filling the drain pan under the unit with water, clean the U-trap and the drain line, if necessary.

5. Supply air flow control (twice per year).

The supply duct grille may get clogged with leaves and other objects reducing the unit performance and supply air delivery. Check the supply grille twice per year and clean it as required.

6. Ductwork system maintenance (once in 5 years).

Even regular fulfilling of all the maintenance operations prescribed above may not completely prevent dirt accumulation in the air ducts, which leads to air pollution and reduces the unit capacity. Duct maintenance means regular cleaning or replacement.

TROUBLESHOOTING



IF UNIDENTIFIED NOISES OR ODOURS SHOULD ARISE AND IN CASE OF DEFORMATION OF ELEMENTS, VIBRATION, TERMINATION OF AIR SUPPLY/EXTRACTION OR REDUCED SYSTEM PERFORMANCE, IMMEDIATELY DISCONNECT THE UNIT FROM POWER SUPPLY AND CONTACT THE SELLER FOR THE VENTILATION SYSTEM DIAGNOSTICS. DIAGNOSTICS MUST BE CARRIED OUT BY QUALIFIED SPECIALISTS

POSSIBLE MALFUNCTIONS AND TROUBLESHOOTING

Problem	Possible reasons	Troubleshooting
The fan(s) does (do) not start when the unit is on.	No power supply.	Make sure the power supply line is connected correctly, otherwise troubleshoot a connection error.
	The mode in which the fans are turned off is set.	Change the mode with the help of the control panel.
Low air flow.	Low set fan speed.	Set higher speed.
	The filters and the fans are clogged, the heat exchanger is clogged.	Clean or replace the filters, clean the fans, and the heat exchanger.
	Ventilation system elements (air ducts, diffusers, louver shutters, grilles) are clogged, damaged or closed.	Clean or replace the ventilation system elements, such as air ducts, diffusers, louver shutters, grilles.
Cold supply air.	The extract filter is soiled.	Clean or replace the extract filter.
Noise, vibration.	The fan or casing screw connection is loose.	Tighten the screw connection of the fans or the casing.
	No anti-vibration connectors on air duct pipe flanges.	Install anti-vibration connectors.
Water leakage (only for RECOM 3 S(F) EC-L/R units)	The drainage system is soiled, damaged, or installed incorrectly.	Clean the drain line. Check the drain line slope angle. Make sure that the U-trap is filled with water and the drain pipes are frost protected.

If troubleshooting steps have failed, contact the Seller of the product.

In case of faults not described in the table, contact the Seller for further information.

STORAGE AND TRANSPORTATION REGULATIONS

- Store the unit in the manufacturer's original packaging box in a dry closed ventilated premise with temperature range +5...+40 °C and relative humidity up to 70 %.
- Storage environment must not contain aggressive vapors and chemical mixtures provoking corrosion, insulation, and sealing deformation.
- Use suitable hoist machinery for handling and storage operations to prevent possible damage to the unit.
- Follow the handling requirements applicable for the particular type of cargo.
- The unit can be carried in the original packaging by any mode of transport provided proper protection against precipitation and mechanical damage. The unit must be transported only in the working position.
- Avoid sharp blows, scratches, or rough handling during loading and unloading.
- Prior to the initial power-up after transportation at low temperatures, allow the unit to warm up at operating temperature for at least 3-4 hours.

MANUFACTURER'S WARRANTY

The product is in compliance with EU norms and standards on low voltage guidelines and electromagnetic compatibility. We hereby declare that the product complies with the provisions of Electromagnetic Compatibility (EMC) Directive 2014/30/EU of the European Parliament and of the Council, Low Voltage Directive (LVD) 2014/35/EU of the European Parliament and of the Council and CE-marking Council Directive 93/68/EEC. This certificate is issued following test carried out on samples of the product referred to above.

The manufacturer hereby warrants normal operation of the unit for 24 months after the retail sale date provided the user's observance of the transportation, storage, installation, and operation regulations. Should any malfunctions occur in the course of the unit operation through the Manufacturer's fault during the guaranteed period of operation, the user is entitled to get all the faults eliminated by the manufacturer by means of warranty repair at the factory free of charge. The warranty repair includes work specific to elimination of faults in the unit operation to ensure its intended use by the user within the guaranteed period of operation. The faults are eliminated by means of replacement or repair of the unit components or a specific part of such unit component.

The warranty repair does not include:

- routine technical maintenance
- unit installation/dismantling
- unit setup

To benefit from warranty repair, the user must provide the unit, the user's manual with the purchase date stamp, and the payment paperwork certifying the purchase. The unit model must comply with the one stated in the user's manual. Contact the Seller for warranty service.

The manufacturer's warranty does not apply to the following cases:

- User's failure to submit the unit with the entire delivery package as stated in the user's manual including submission with missing component parts previously dismantled by the user.
- Mismatch of the unit model and the brand name with the information stated on the unit packaging and in the user's manual.
- User's failure to ensure timely technical maintenance of the unit.
- External damage to the unit casing (excluding external modifications as required for installation) and internal components caused by the user.
- Redesign or engineering changes to the unit.
- Replacement and use of any assemblies, parts and components not approved by the manufacturer.
- Unit misuse.
- Violation of the unit installation regulations by the user.
- Violation of the unit control regulations by the user.
- Unit connection to power mains with a voltage different from the one stated in the user's manual.
- Unit breakdown due to voltage surges in power mains.
- Discretionary repair of the unit by the user.
- Unit repair by any persons without the manufacturer's authorization.
- Expiration of the unit warranty period.
- Violation of the unit transportation regulations by the user.
- Violation of the unit storage regulations by the user.
- Wrongful actions against the unit committed by third parties.
- Unit breakdown due to circumstances of insuperable force (fire, flood, earthquake, war, hostilities of any kind, blockades).
- Missing seals if provided by the user's manual.
- Failure to submit the user's manual with the unit purchase date stamp.
- Missing payment paperwork certifying the unit purchase.



FOLLOWING THE REGULATIONS STIPULATED HEREIN WILL ENSURE A LONG AND TROUBLE-FREE OPERATION OF THE UNIT.



USER'S WARRANTY CLAIMS SHALL BE SUBJECT TO REVIEW ONLY UPON PRESENTATION OF THE UNIT, THE PAYMENT DOCUMENT AND THE USER'S MANUAL WITH THE PURCHASE DATE STAMP.

CERTIFICATE OF ACCEPTANCE

Unit Type	Air handling unit
Model	
Serial Number	
Manufacture Date	
Quality Inspector's Stamp	

SELLER INFORMATION

Seller	
Address	
Phone Number	
E-mail	
Purchase Date	
This is to certify acceptance of the complete unit delivery with the user's manual. The warranty terms are acknowledged and accepted.	
Customer's Signature	

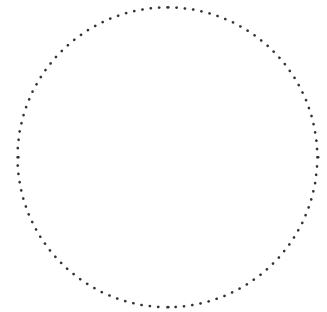

Seller's Stamp

INSTALLATION CERTIFICATE

The unit _____ is installed pursuant to the requirements stated in the present user's manual.	
Company name	
Address	
Phone Number	
Installation Technician's Full Name	
Installation Date:	Signature:
The unit has been installed in accordance with the provisions of all the applicable local and national construction, electrical and technical codes and standards. The unit operates normally as intended by the manufacturer.	
Signature:	

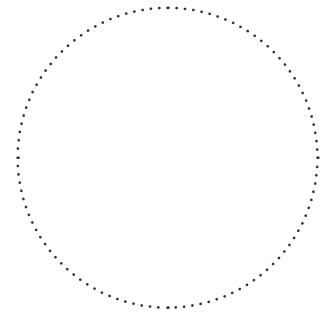

Installation Stamp

WARRANTY CARD

Unit Type	Air handling unit
Model	
Serial Number	
Manufacture Date	
Purchase Date	
Warranty Period	
Seller	

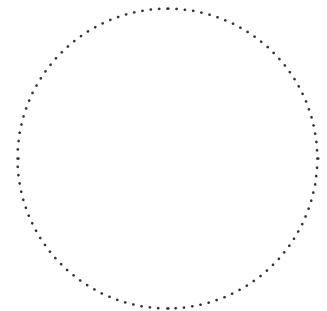

Seller's Stamp

